

ELECTRIC PUMPS

BETEX EP13 SERIES, ELECTRIC HYDRAULIC PUMPS, 3 LITER, 700 BAR

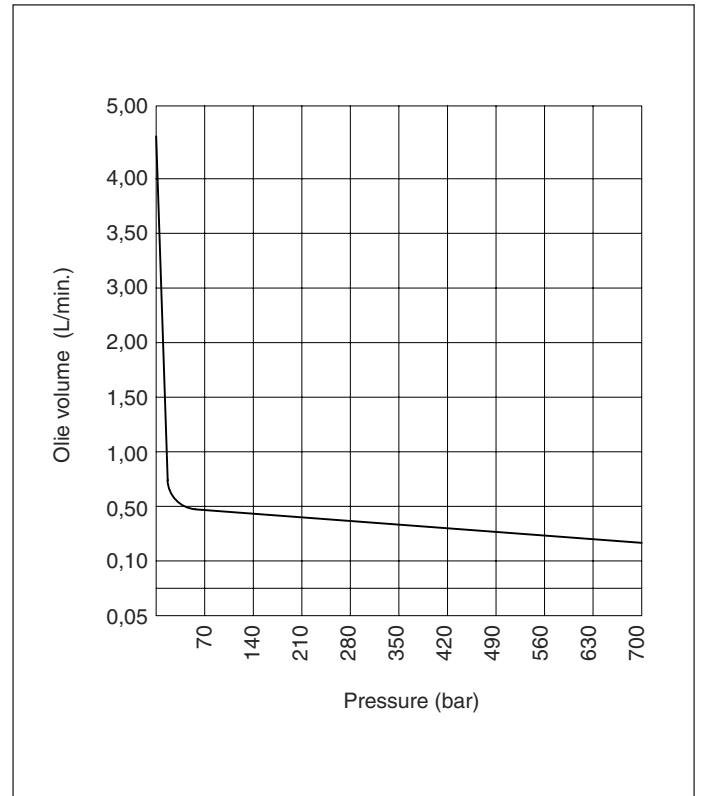

EP13S

- Electric pump 230V, 5A, 50/60 Hz universal induction motor, thermal protected
- Very quiet (about 80dBA at 700 Bar)
- Remote control incl cord (3m)
- Automatic overload-relief valve (700 bar) protects components in hydraulic systems and ensures safe operation
- Specially designed EP13D is for double-acting cylinders without the need for extra controlling valve and adapters

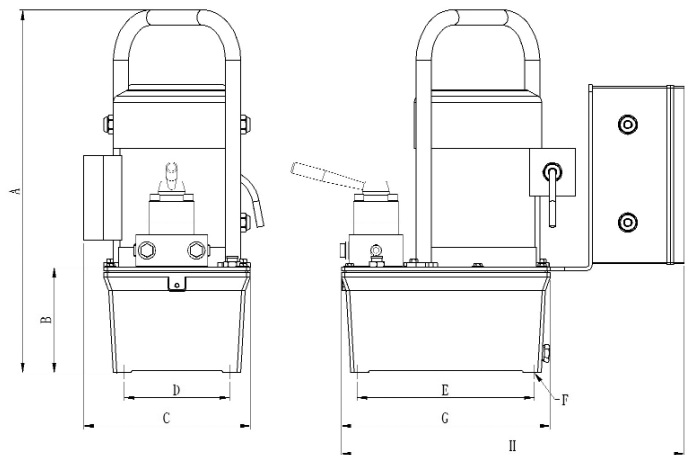

EP13 series

Type	Valve	Valve function	Motor
EP13S	2 pos./ 2-way	Hold / return	0.37kW, 230V/5A 50/60Hz, Single phase
EP13D	3 pos./ 4-way	Advance / hold return	

TIP! Use in combination with accessories, page 70-74

Type	Acting	Content reservoir (liter)	Usable oil (liter)	Max. pressure (bar)	Oil volume (l/min. @60Hz)				A mm	B mm	C mm	D mm	E mm	F mm	G mm	H mm	Weight Kg
					0 bar	7 bar	350 bar	700 bar									
EP13S	single	3	2,8	700	4.2	2.8	0.33	0.3	512	149	236	149,5	251	1/4"- 20UNC 10 deep	296	485	26,5
EP13D	double	3	2,8	700	4.2	2.8	0.33	0.3	512	149	236	149,5	251	1/4"- 20UNC 10 deep	296	485	26,5

ELECTRIC PUMPS

BETEX EP18 SERIES, ELECTRIC-HYDRAULIC PUMPS, 8 LITER, 700 BAR

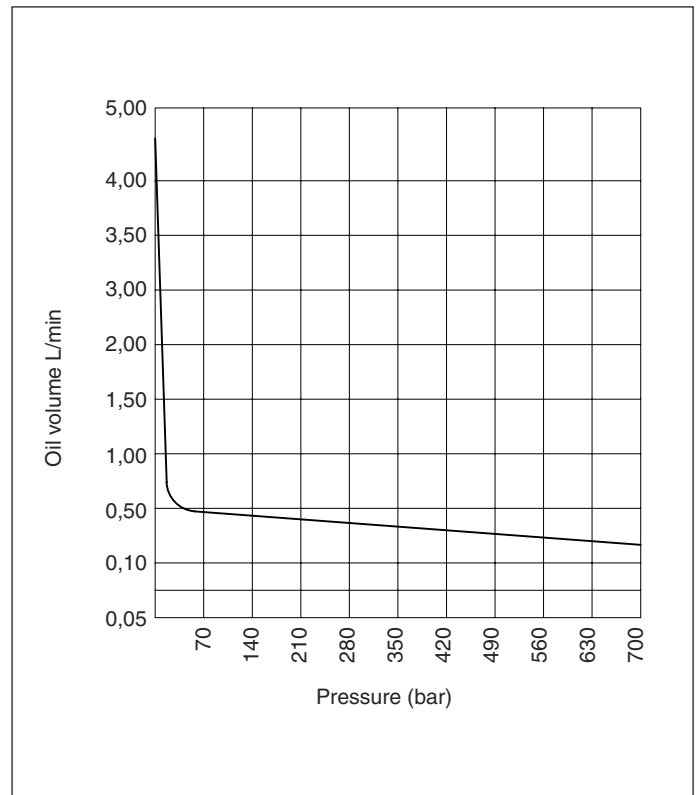

EP18D

- Electric pump 230V 50/60 Hz universal induction motor, thermal protected
- Very quiet (about 80dBA at 700 bar)
- Remote control incl cord (3m)
- Automatic 700 bar overload-relief valve protects components in hydraulic systems and ensures safe operation
- Specially designed EP18D is for double-acting cylinders without the need for extra controlling valve and adapters
- Type EP18SS and EP18DS are fitted with a solenoid valve

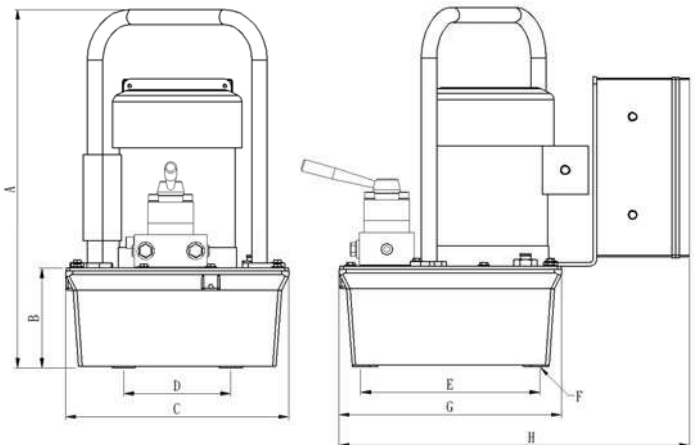

EP18 series

Type	Valve	Valve function	Motor
EP18S(S*)	2 pos./ 2-way	Hold / return	0.37kW, 230V/10A 50/60Hz, Single phase
EP18D(S*)	3 pos./ 4-way	Advance / hold return	

TIP! Use in combination with accessories, page 70-74

Type	Acting	Content reservoir (liter)	Usable oil (liter)	Max. pressure (bar)	Oil volume (l/min. @60Hz)			A mm	B mm	C mm	D mm	E mm	F mm	G mm	H mm	Weight Kg	
					0 bar	7 bar	350 bar										700 bar
EP18S(S*)	single	8	6	700	4.2	2.8	0.33	0.3	505	142	312	149,5	251	1/4"- 20UNC 10 deep	312	492	31
EP18D(S*)	double	8	6	700	4.2	2.8	0.33	0.3	505	142	312	149,5	251	1/4"- 20UNC 10 deep	312	492	31

The models with a * are fitted with a solenoid valve.



ELECTRIC PUMPS

BETEX EP211 SERIES, ELECTRIC HYDRAULIC PUMPS, 11 LITER, 700 BAR

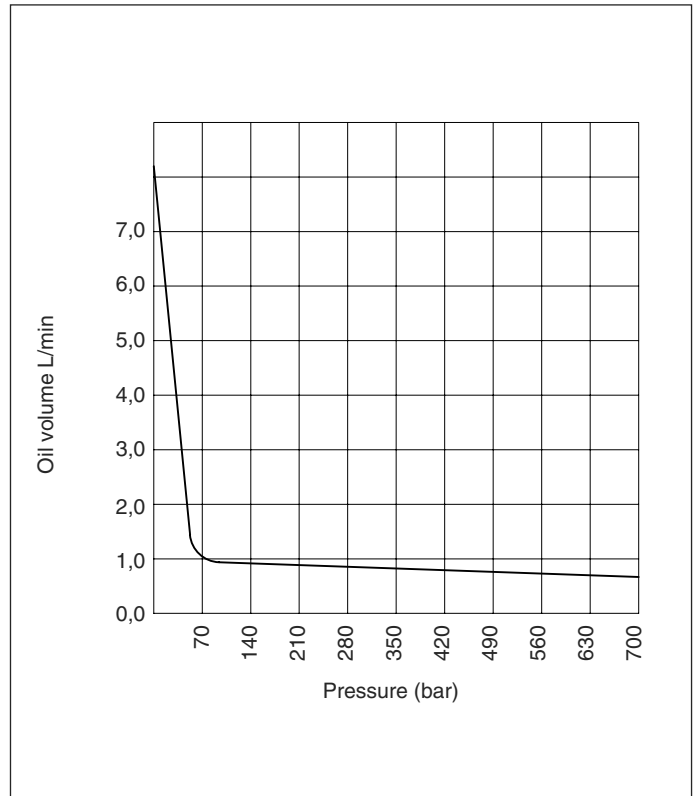

EP211D

- Electric pump 230V 50/60 Hz universal induction motor, thermal protected
- Very quiet (about 80dBA at 700 bar)
- Remote control incl cord (3m)
- Automatic 700 bar overload-relief valve protects components in hydraulic systems and ensures safe operation
- Specially designed EP211D is for double-acting cylinders without the need for extra controlling valve and adapters
- Type EP211SS and EP211DS are fitted with a solenoid valve

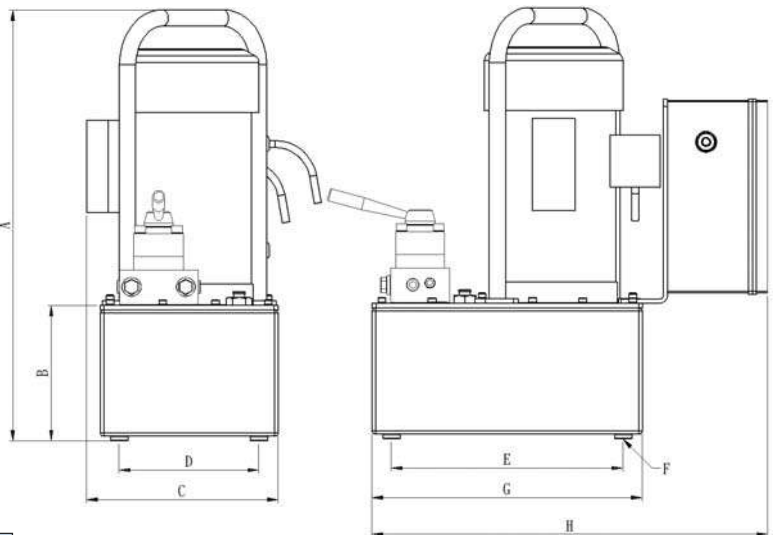

EP211 series

Type	Valve	Valve function	Motor
EP211S(S*)	2 pos./ 2-way	Hold / return	1.12kW, 230V/12A 50/60Hz, Single phase
EP211D(S*)	3 pos./ 4-way	Advance / hold return	

TIP! Use in combination with accessories, page 70-74

Type	Acting	Content reservoir (liter)	Usable oil (liter)	Max. pressure (bar)	Oil volume (l/min. @60Hz)				A mm	B mm	C mm	D mm	E mm	F mm	G mm	H mm	Weight Kg
					0 bar	7 bar	350 bar	700 bar									
EP211S(S*)	single	11	8,5	700	8.2	7.4	0.84	0.75	560	176	247	180	300	1/2"- 20UNF 15 deep	350	512,5	37
EP211D(S*)	double	11	8,5	700	8.2	7.4	0.84	0.75	560	176	247	180	300	1/2"- 20UNF 15 deep	350	512,5	37

The models with a * are fitted with a solenoid valve.

ELEKTRISCHE POMPEN

BETEX EP320 SERIES, ELECTRIC HYDRAULIC PUMPS, 20 LITER, 700 BAR

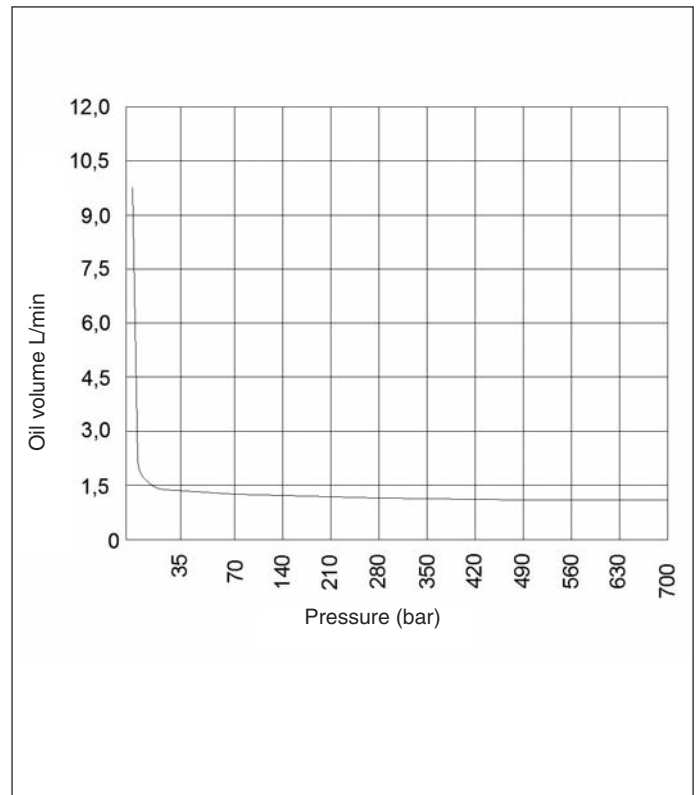

EP320S

- Electric pump 400V, 5A, 50/60 Hz universal induction motor, thermal protected
- Very quiet (about 80dBA at 700 Bar)
- Remote control incl cord (3m)
- Automatic overload-relief valve (700 bar) protects components in hydraulic systems and ensures safe operation
- Specially designed EP320D is for double-acting cylinders without the need for extra controlling valve and adapters

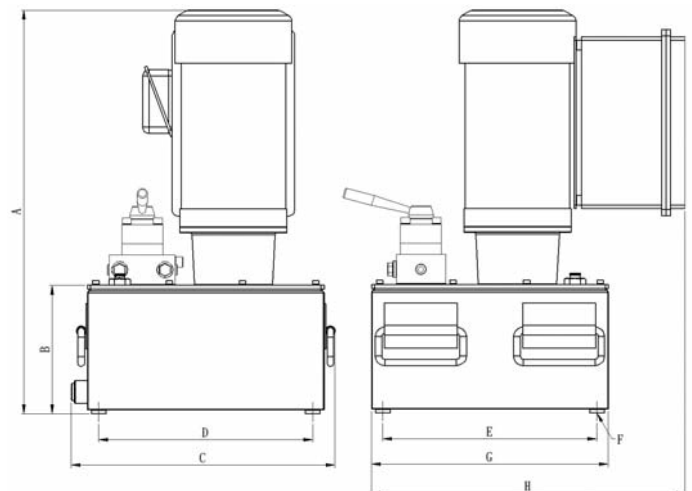

EP320 series

Type	Valve	Valve function	Motor
EP320S	2 pos./ 2-way	Hold / return	1.49kW 400V 5A
EP320D	3 pos./ 4-way	Advance / hold return	50/60Hz 3 phase

TIP! Use in combination with accessories, page 70-74

Type	Acting	Content reservoir (liter)	Usable oil (liter)	Max. pressure (bar)	Oil volume (l/min. @60Hz)			A mm	B mm	C mm	D mm	E mm	F mm	G mm	H mm	Weight Kg	
					7 bar	70 bar	350 bar										700 bar
EP320S	single	20	15	700	9.5	1.1	1.06	0.98	630	199	407	330	330	1/2" - 20UNF 19 deep	365	483	54
EP320D	double	20	15	700	9.5	1.1	1.06	0.98	630	199	407	330	330	1/2" - 20UNF 19 deep	365	483	54

ELECTRIC PUMPS

BETEX EP420 SERIES, ELECTRIC HYDRAULIC PUMPS, 20 LITER, 700 BAR

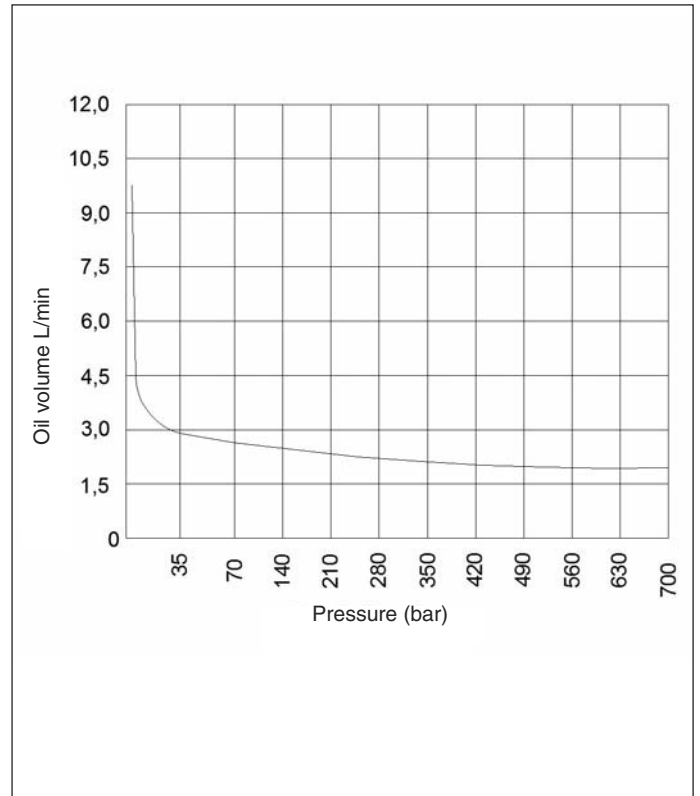

EP420D

- Electric pump 400V, 6A, 50/60 Hz universal induction motor, thermal protected
- Very quiet (about 80dBA at 700 Bar)
- Remote control incl cord (3m)
- Automatic overload-relief valve (700 bar) protects components in hydraulic systems and ensures safe operation
- Specially designed EP420D is for double-acting cylinders without the need for extra controlling valve and adapters

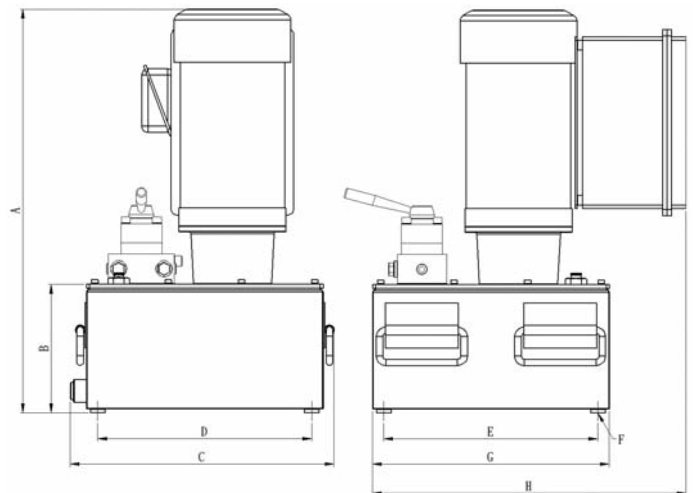

EP420 series

Type	Valve	Valve function	Motor
EP420S	2 pos./ 2-way	Hold / return	2.24kW 400V 6A
EP420D	3 pos./ 4-way	Advance / hold return	50/60Hz 3 phase

TIP! Use in combination with accessories, page 70-74

Type	Acting	Content reservoir (liter)	Usable oil (liter)	Max. pressure (bar)	Oil volume (l/min. @60Hz)			A mm	B mm	C mm	D mm	E mm	F mm	G mm	H mm	Weight Kg	
					7 bar	70 bar	350 bar										700 bar
EP420S	single	20	15	700	9.5	2.6	2.1	1.95	630	199	407	330	330	1/2" - 20UNF 19 deep	365	483	59
EP420D	double	20	15	700	9.5	2.6	2.1	1.95	630	199	407	330	330	1/2" - 20UNF 19 deep	365	483	59